

Current Transducer LTC 1000-SF/SP33

For the electronic measurement of currents: DC, AC, pulsed..., with galvanic separation between the primary circuit and the secondary circuit.

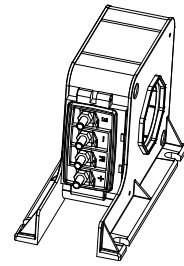

$$I_{PN} = 1000 \text{ A}$$



Electrical data

I_{PN}	Primary nominal rms current	1000	A			
I_{PM}	Primary current, measuring range @ $\pm 24 \text{ V}$	0 ... ± 3000	A			
R_M	Measuring resistance	$R_{M \min}$	$R_{M \max}$			
		with $\pm 15 \text{ V}$	@ $\pm 1000 \text{ A}_{\max}$	0	20	Ω
			@ $\pm 1500 \text{ A}_{\max}$	0	4	Ω
		with $\pm 24 \text{ V}$	@ $\pm 1000 \text{ A}_{\max}$	2	60	Ω
	@ $\pm 3000 \text{ A}_{\max}$	2	2	Ω		
I_{SN}	Secondary nominal rms current	250	mA			
K_N	Conversion ratio	1 : 4000				
U_C	Supply voltage ($\pm 5 \%$)	$\pm 15 \dots 24$	V			
I_C	Current consumption	$33 (@ \pm 24 \text{ V}) + I_S$	mA			

Accuracy - Dynamic performance data

X_G	Overall accuracy @ I_{PN} , $T_A = 25 \text{ }^\circ\text{C}$	$< \pm 0.4$	%	
ϵ_L	Linearity error	< 0.1	%	
		Max		
I_O	Offset current @ $I_P = 0$, $T_A = 25 \text{ }^\circ\text{C}$	± 0.5	mA	
I_{OT}	Temperature variation of I_O	-40 $^\circ\text{C}$... +85 $^\circ\text{C}$	± 1	mA
t_r	Step response time ¹⁾ to 90 % of I_{PN}	< 1	μs	
di/dt	di/dt accurately followed	> 100	A/ μs	
BW	Frequency bandwidth (-1 dB)	DC ... 100	kHz	

General data

T_A	Ambient operating temperature	-40 ... +85	$^\circ\text{C}$
T_S	Ambient storage temperature	-50 ... +90	$^\circ\text{C}$
R_S	Resistance of secondary winding @ $T_A = 85 \text{ }^\circ\text{C}$	26	Ω
m	Mass	840	g
	Standards	EN 50155: 2007 UL 508: 2013	

Note: ¹⁾ With a di/dt of 100 A/ μs .

Features

- Closed loop (compensated) current transducer using the Hall effect
- Insulating plastic case recognized according to UL 94-V0.

Special features

- $I_{PM} = 0 \dots \pm 3000 \text{ A}$
- $K_N = 1 : 4000$
- Mounting feet compatible with LT 1000-SI/SP11
- Mounting base included
- Current direction.

Advantages

- Excellent accuracy
- Very good linearity
- Low temperature drift
- Optimized response time
- Wide frequency bandwidth
- No insertion losses
- High immunity to external interference
- Current overload capability.

Applications

- Single or three phase inverters
- Propulsion and braking choppers
- Propulsion converters
- Auxiliary converters
- Battery chargers.

Application Domain

- Traction.

Current Transducer LTC 1000-SF/SP33

Insulation coordination

U_d	Rms voltage for AC insulation test, 50 Hz, 1 min	13.4 ¹⁾	kV
		1.5 ²⁾	kV
U_e	Partial discharge extinction rms voltage @ 10 pC	> 2.8	kV
		Min	
d_{cp}	Creepage distance	55.5	mm
d_{cl}	Clearance	45	mm
CTI	Comparative tracking index (group I)	600	

Notes: ¹⁾ Between primary and secondary + shield

²⁾ Between secondary and shield.

Safety



This transducer must be used in electric/electronic equipment with respect to applicable standards and safety requirements in accordance with the manufacturer's operating instructions.



Caution, risk of electrical shock

When operating the transducer, certain parts of the module can carry hazardous voltage (eg. primary busbar, power supply).

Ignoring this warning can lead to injury and/or cause serious damage.

This transducer is a build-in device, whose conducting parts must be inaccessible after installation.

A protective housing or additional shield could be used.

Main supply must be able to be disconnected.

Dimensions LTC 1000-SF/SP33 (in mm)

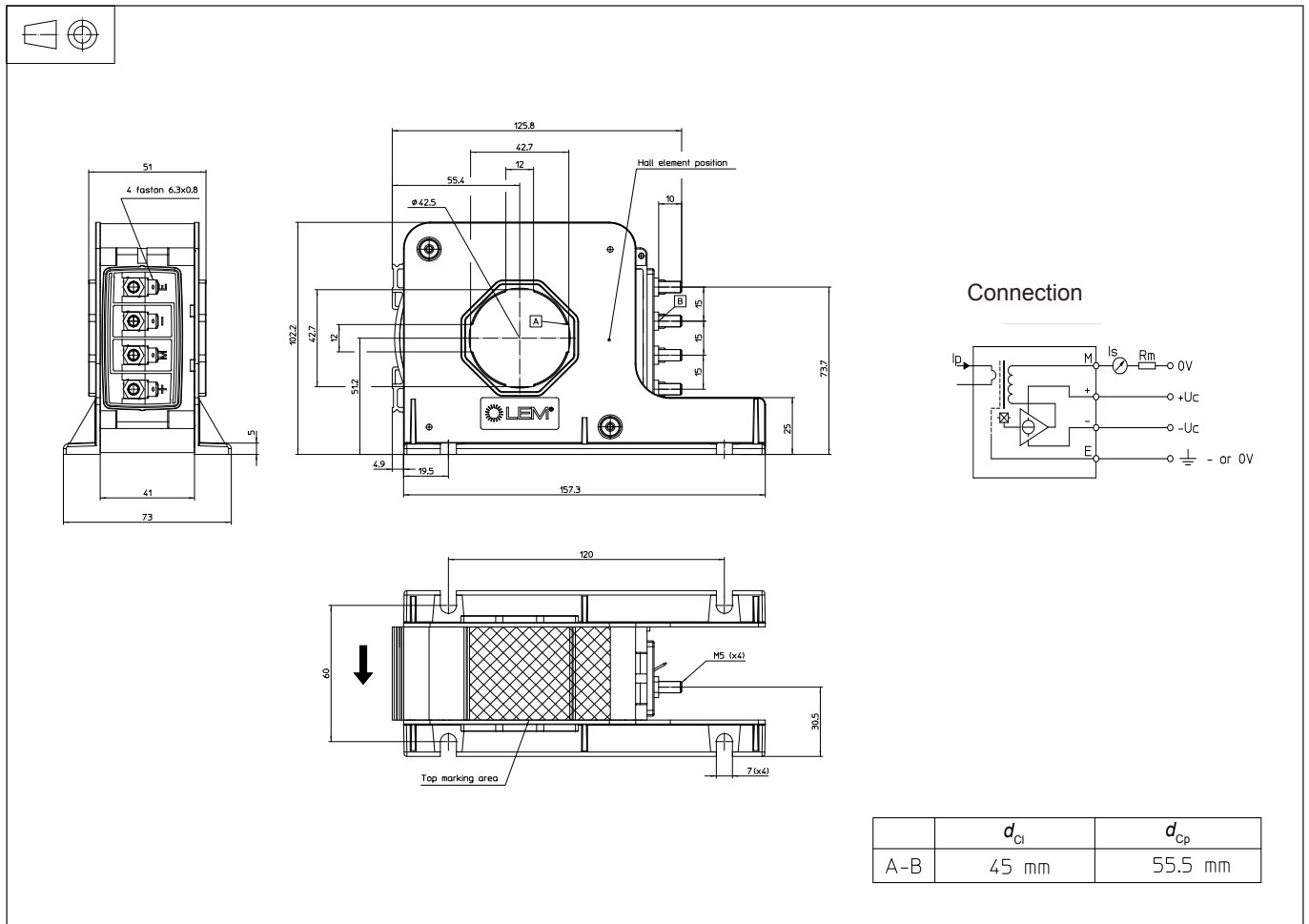

Mechanical characteristics

- General tolerance ± 1 mm
- Transducer fastening
 - 4 notches $\varnothing 7$ mm
 - 4 M6 steel screws
- Recommended fastening torque 4.7 N·m (± 10 %)
- Connection of secondary
 - 4 M5 threaded studs
 - Recommended fastening torque 2.2 N·m
 - Faston 6.3 × 0.8 mm

Remarks

- I_s is positive when I_p flows in the direction of the arrow.
- Temperature of the primary conductor should not exceed 100 °C.
- Installation of the transducer must be done unless otherwise specified on the datasheet, according to LEM Transducer Generic Mounting Rules. Please refer to LEM document N°ANE120504 available on our Web site: [Products/Product Documentation](#).